



# MiniFogger® III

Economical, efficient humidification unit designed for use when space is tight



## Benefits

- Compact and lightweight – ideal for use in hard-to-reach areas such as corners, walls and ceilings. At just 4.5" (115 mm) tall, MiniFogger III fits easily in the palm of your hand
- Energy-efficient operation – uses less compressed air than other units while producing very small drops in the 6.7 to 12 micron size for fast evaporation
- Materials of construction offer good chemical resistance and are suitable for use with deionized water
- Choice of stainless steel flat spray set-ups for flow rates ranging from 0.24 to 1.22 gph (0.9 to 4.6 l/hr)
- Automatic spray pattern alignment
- Easy to maintain – no tools required

## Specifications

Maximum liquid flow rate: 1.22 gph (4.6 l/hr) at 0.4 MPa (58 psi/4 bar) per set-up

Materials of construction: Polypropylene body  
Stainless steel spray set-ups

Maximum operating air pressure: 0.4 MPa (58 psi/4 bar)

Inlet connections:  
Air: 1/4" NPT or BSPT (F)  
Water: 1/8" NPT or BSPT (F)

Height: 4.5" (115 mm)

Diameter: 3.1" (80 mm)

Weight: 0.46 lb (207 g)

## Typical Applications



Textiles



Food Processing



Storage Facilities

Printing  
Furniture Manufacturing

# MiniFogger® III

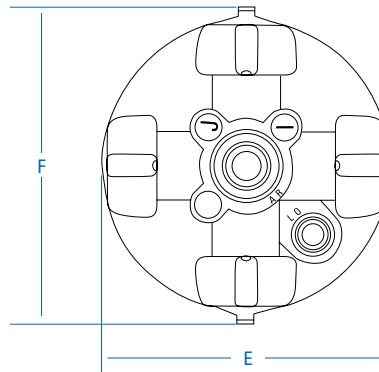
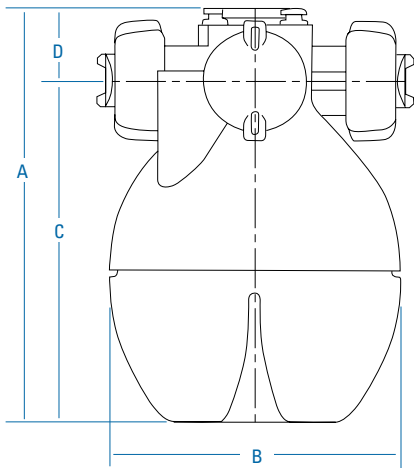

## Dimensions

Model No.	A in. (mm)	B in. (mm)	C in. (mm)	D in. (mm)	E in. (mm)	F in. (mm)
YMF-3	4.5 (115)	3.1 (80)	3.7 (95)	.8 (20)	3.1 (80)	3.4 (86.8)

## Performance Data

Normal Type	Air Volume [L(normal)/min]			Flow Rate gallons per hour (liters per hour)			Sauter Mean Dia. (µm)		
	0.25 MPa 36 psi (2.5 bar)	0.3 MPa 44 psi (3 bar)	0.4 MPa 58 psi (4 bar)	0.25 MPa 36 psi (2.5 bar)	0.3 MPa 44 psi (3 bar)	0.4 MPa 58 psi (4 bar)	0.25 MPa 36 psi (2.5 bar)	0.3 MPa 44 psi (3 bar)	0.4 MPa 58 psi (4 bar)
SU1.0N	1.1 scfm (30)	1.2 scfm (35)	1.6 scfm (45)	.24 (.9)	.26 (1.0)	.29 (1.1)	8.5	7.6	6.7
SU2.5N				.61 (2.3)	.66 (2.5)	.69 (2.6)	9.6	8.5	7.6
SU3.0N				.74 (2.8)	.79 (3.0)	.85 (3.2)	9.8	9.0	8.4
SU4.5N				1.06 (4.2)	1.14 (4.5)	1.22 (4.8)	12.2	11.6	10.8

The standard MiniFogger III has four spray set-ups. Single spray set-ups are available. Contact your local representative for more information.

## Ordering Information

MiniFogger III			
<b>Y M F - 3 - 4 + S U 3 . 0 N - S S</b>			
Humidification Unit Type	No. of Set-ups	Set-up No.	Material Code



**Spraying Systems Co.®**  
Experts in Spray Technology

SSCO-Spraying Systems AG  
Eichenstrasse 6 · Postfach 27  
CH-8808 Pfäffikon SZ · Switzerland

Tel. +41 - 55 - 410 10 60 · Fax +41 - 55 - 410 39 30  
Email: info.ch@spray.com · Web: www.scco.ch



**Spraying Systems Co.®**  
Experts in Spray Technology

North Avenue and Schmale Road, P.O. Box 7900, Wheaton, IL 60187-7901 USA

Tel: 1.800.95.SPRAY Intl. Tel: 1.630.665.5000

Fax: 1.888.95.SPRAY Intl. Fax: 1.630.260.0842

www.spray.com



Spray  
Nozzles



Spray  
Control



Spray  
Analysis



Spray  
Fabrication

